

DAFTAR PUSTAKA

- Anonim. (2018). Buku Pedoman Praktik Kerja Lapangan Akademi Komunitas Industri Tekstil Dan Produk Tekstil Surakarta
- Anonim. (2018-2020). Perjanjian Kerja Bersama PT. Prima Sejati Sejahtera. Boyolali.
- BOM (*Bill Of Material*) *Jacket Style* WE1520.
- Data *Report Defect* Periode Agustus di *line sewing* 30 dengan *style* WE1520
- PT. Pan Brothers, Tbk. (2018). *Annual Report*. Tangerang.
- SOP yang berlaku di PT. Prima Sejati Sejahtera 2.
- (2019). IDN Financials PT. Pan Brothers, Tbk.

LAMPIRAN

Lampiran 1 Sketsa tampak depan *Jacket Style WE520*

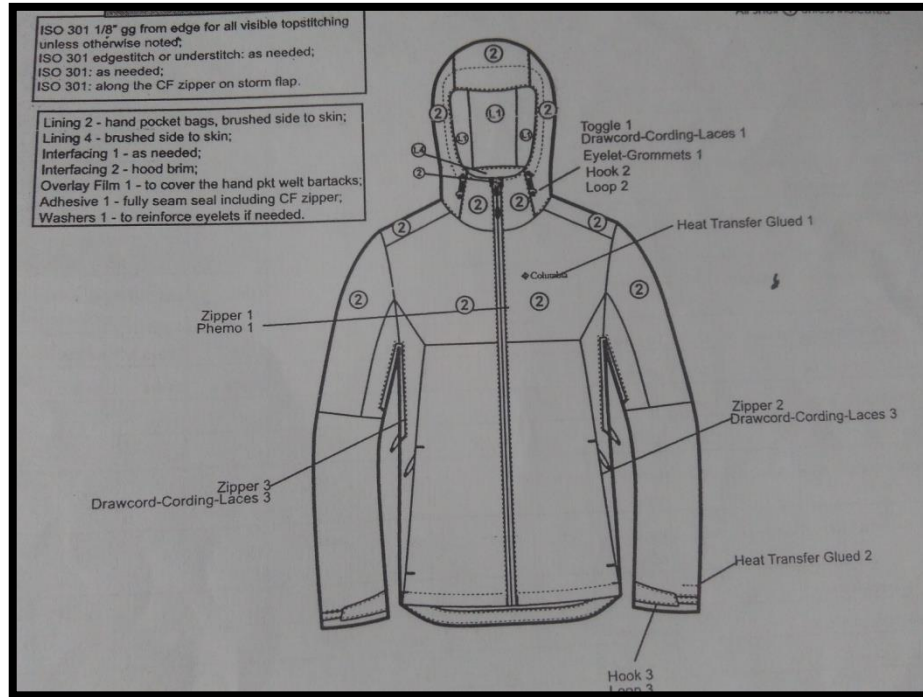

Lampiran 2 Sketsa tampak belakang *Jacket Style WE520*

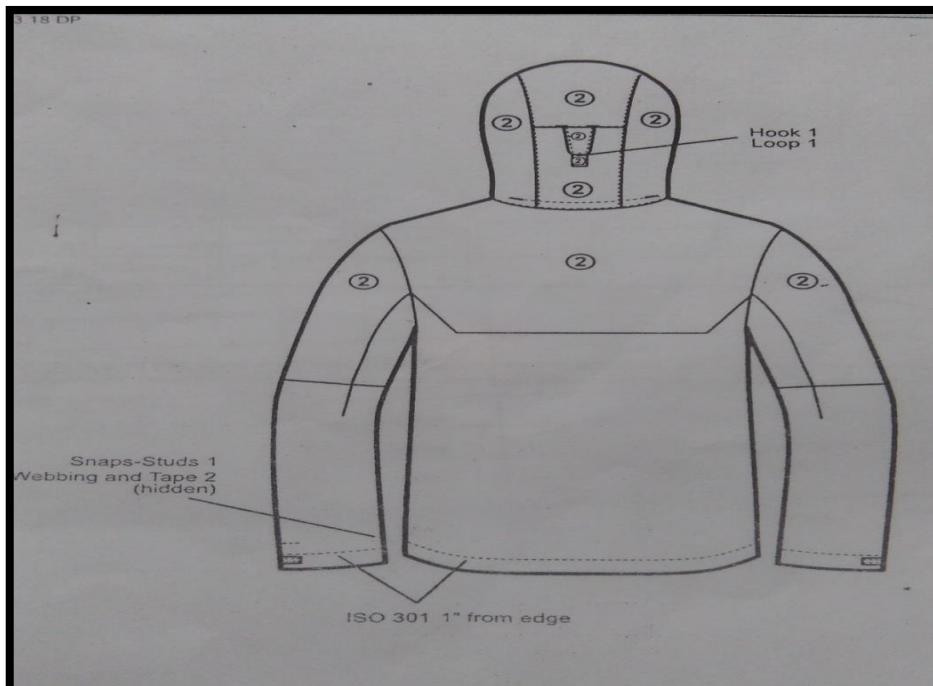

Lampiran 3 Sketsa *Lining dan Lining Hood Jacket Style WE520*

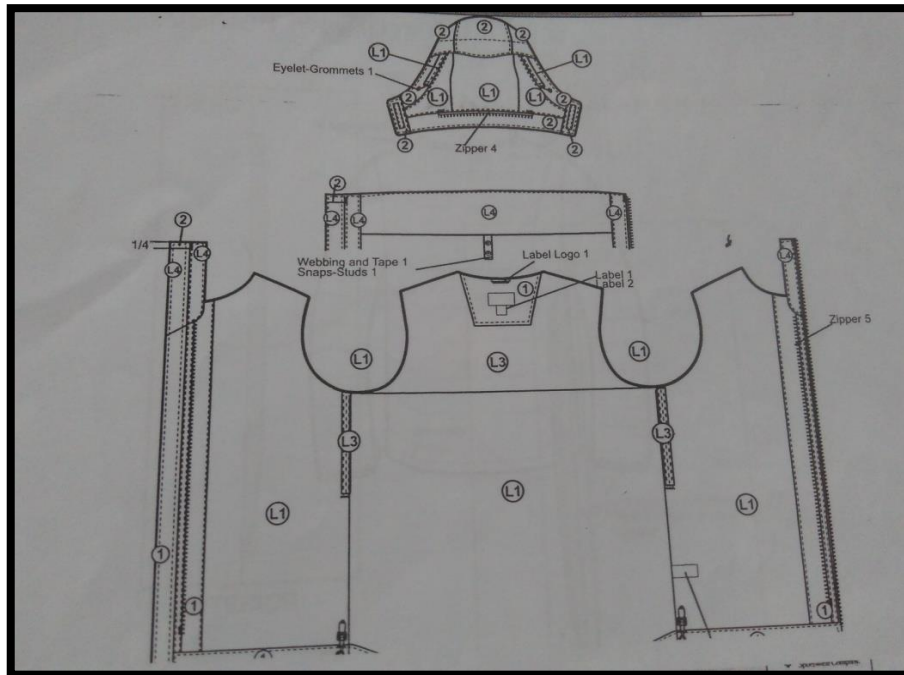

Lampiran 4 Sketsa *Hood Jacket Style WE520*

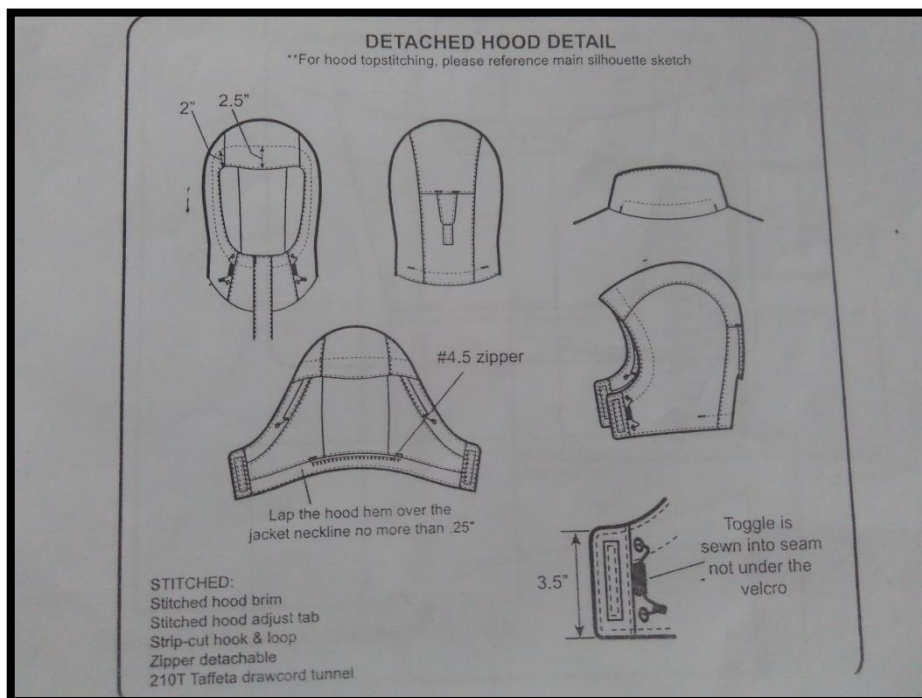

Lampiran 5 Foto KP (kartu produksi) Jacket Style WE520

Style #: WE1520 Season / Buy: F19 FEB 28 BUY 2019 MD: FOB/FY: PRT
 K/P #: COLM190264 Qty: 11,692 pcs Item Name: MENS CASCADE PEAK IV INTERCHAN

Style Identification: Woven Jacket Padded Poly down Fleece Lines Create Date: 01 Mar 19
 Duck down Ball fiber Reversible Unlined

Complexity Factor: Printing Embroidery Quilting Bonding Ultrasonic seam
 Heat transfer Seam sealed Washing

1. Buyer PO: 4500133899 Dest: CHINA - 4158 Country: A-PR2-0919-00213
 Qty: 11,692 pcs Del Date: Mon, 15 Jul 2019 Ship Mode: SEA

	S	M	L	XL	XXL	Total
478/478 DARK MOUNTAIN, COLLEGIAT	954	2615	2996	1889	824	9,278
705/011 GOLDEN YELLOW, SHARKSHA	336	755	779	437	107	2,414
Total	1290	3370	3775	2326	931	11,692

Total Assortment	S	M	L	XL	XXL	Total
478/478 DARK MOUNTAIN, COLLEGIAT	954	2615	2996	1889	824	9,278
705/011 GOLDEN YELLOW, SHARKSHA	336	755	779	437	107	2,414
Total	1290	3370	3775	2326	931	11,692

Total Assortment	S	M	L	XL	XXL	Total
Del Date						
15-Jul-19	1,290.00	3,370.00	3,775.00	2,326.00	931.00	11,692.00
Total	1290	3370	3775	2326	931	11,692

Additional Info: Payment Terms: Label Notes: Page 1 of 1

15 May 2019 18:11:17

Lampiran 6 report defect dari QC end line

Agustus 2019

LINE	STYLE	TOTAL DEFECT GARMENT	TOTAL INSPECT GARMENT	% Defect per item	BY GARMENT	BY RT	BY GARMENT	BALANCE TO BE REPAIRED	CUTTING QC	A	B	C	D	E	F	G	H	I	J	K	L	M	N	O	P	Q	R	S	T	U	V	W	X	Y	Z
30	WE1520	37	2231	1.65%	2194	98.34%	37	0	2231	0	0.00%	0	0.00%	0	0.00%	0	0.00%	0	0.00%	0	0.00%	0	0.00%	0	0.00%	0	0.00%	0	0.00%	0	0.00%	0	0.00%	0	0.00%

PT. PRIMA SEJATI BEJANTERA
 REKAPITULASI DAILY ENDLINE QC REPORT
 PPS 2

DEFECT CLASSIFICATION

E1	%	E2	%	E3	%	E4	%	E5	%	E6	%	E7	%	E8	%	E9	%	F1	%	F2	%	F3	%	F4	%	F5	%	F6	%	F7	%	F8	%	F9	%		
1	0.04%	7	0.31%	0	0.00%	1	0.04%	0	0.00%	2	0.09%	3	0.13%	4	0.04%	3	0.13%	0	0.00%	0	0.00%	0	0.00%	2	0.09%	0	0.00%	0	0.00%	0	0.00%	0	0.00%	0	0.00%	0	0.00%

%	H3	%	I1	%	I2	%	I3	%	I4	%	J1	%	J2	%	J3	%	K1	%	K2	%	K3	%
0.00%	7	0.31%	0	0.00%	0	0.00%	0	0.00%	0	0.00%	0	0.00%	0	0.00%	0	0.00%	0	0.00%	0	0.00%	0	0.00%

J1 = Emb / Printing
 J2 = Hole / Labeling
 J3 = Fold Off
 K1 = Washing
 K2 = DYE color
 K3 = color bleeding/ transfer
 K4 = Hand test